

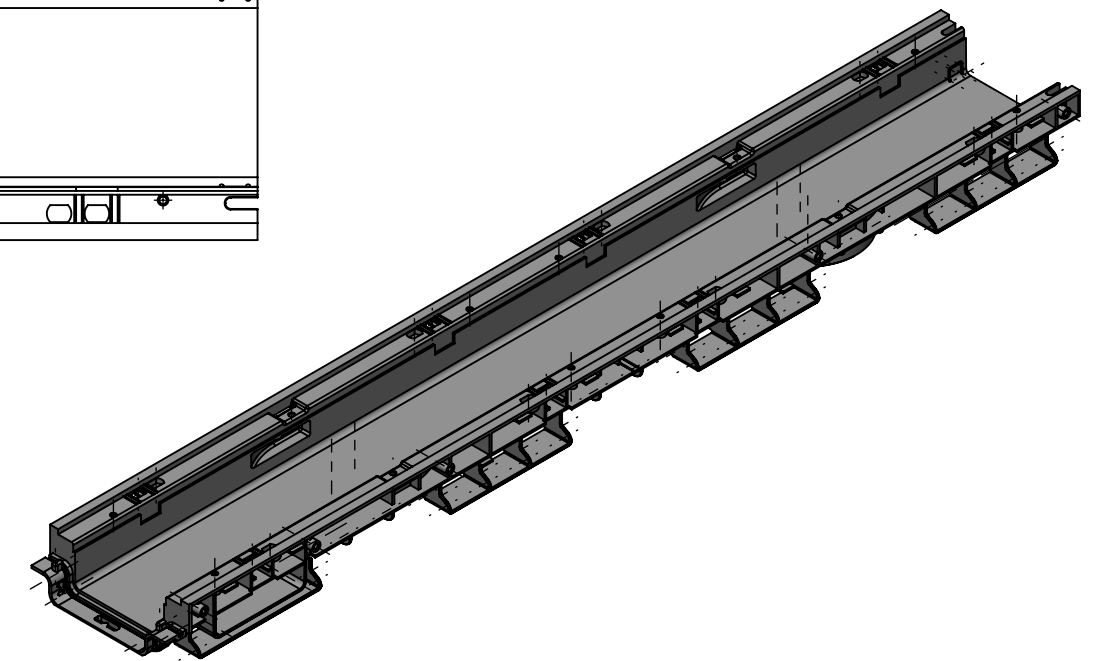

Primary Usage
Reference No.
Sign. and date
Copy inv. No.
Repl. Inv. No.
Sign. and date
Orig. Inv. No.

4" Plastic Channel

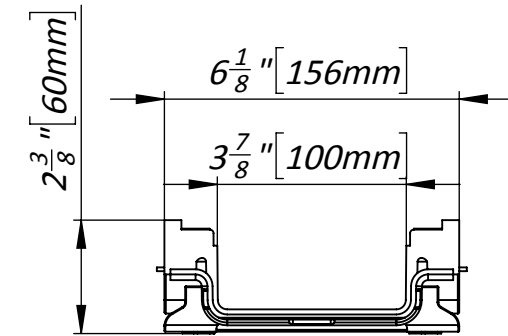
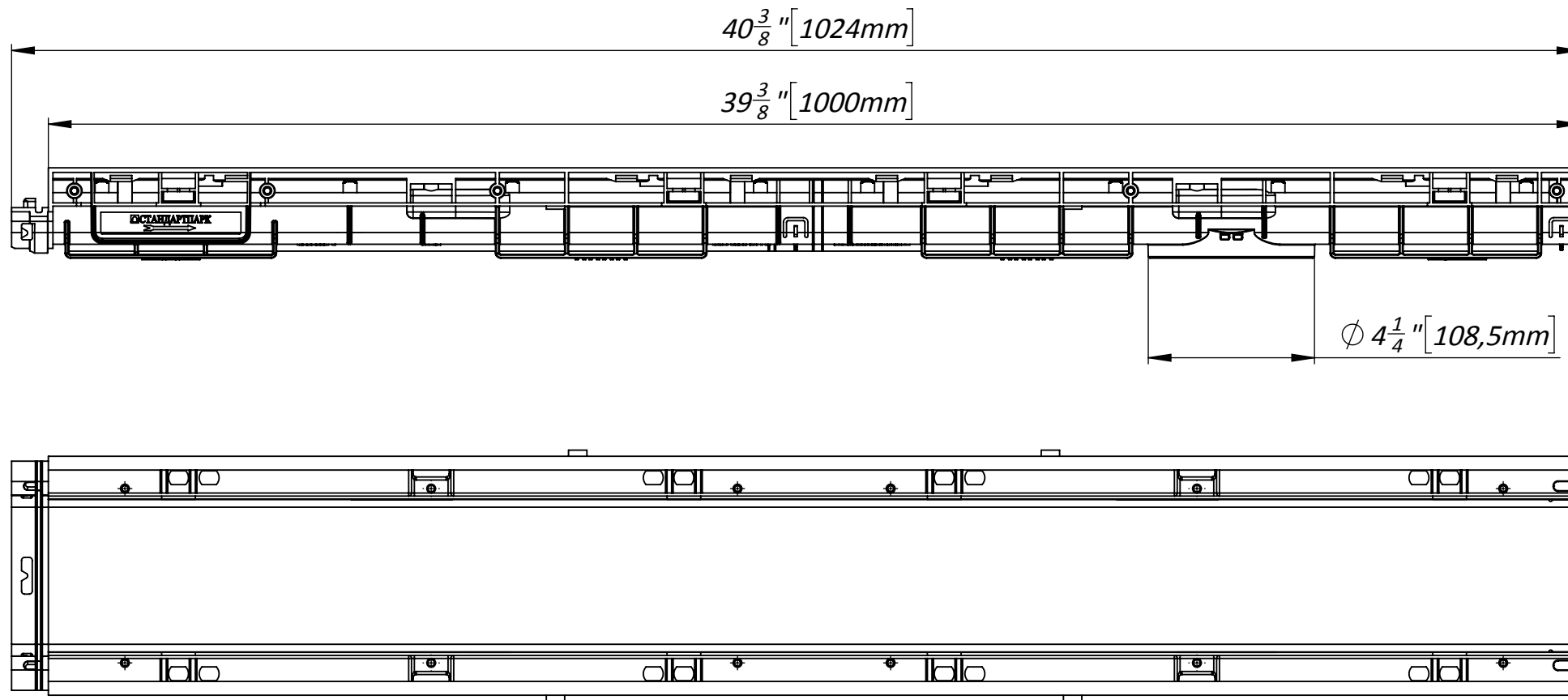

Deviation of the actual weight of the nominal can be up to 10%

					Art. 8050-M			
					4" Plastic Channel			
Rev.	Sheet	Doc. No.	Sign.	Data	8050-M	Let.	Weight (lb)	Scale
				11.09.18			2.04	1:4
					Load Class C	Sheet	Sheets 1	
					Plastic			

6 5 4 3 2 1

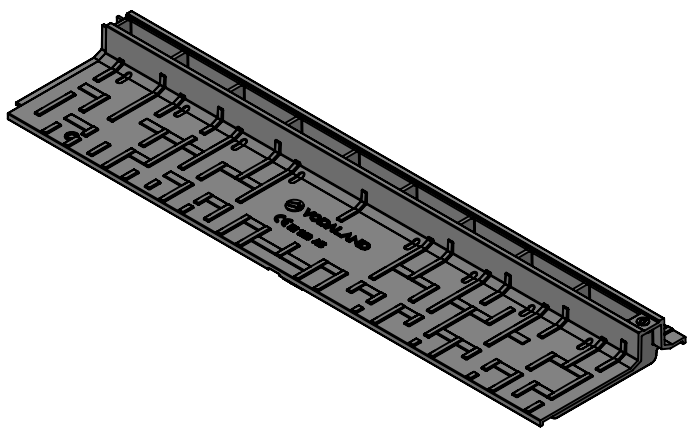
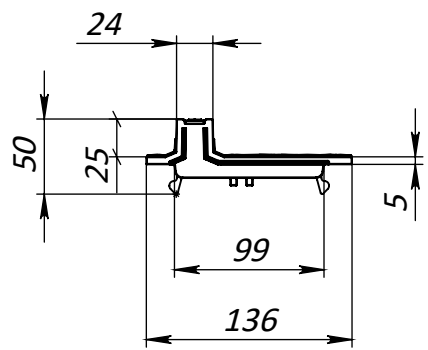
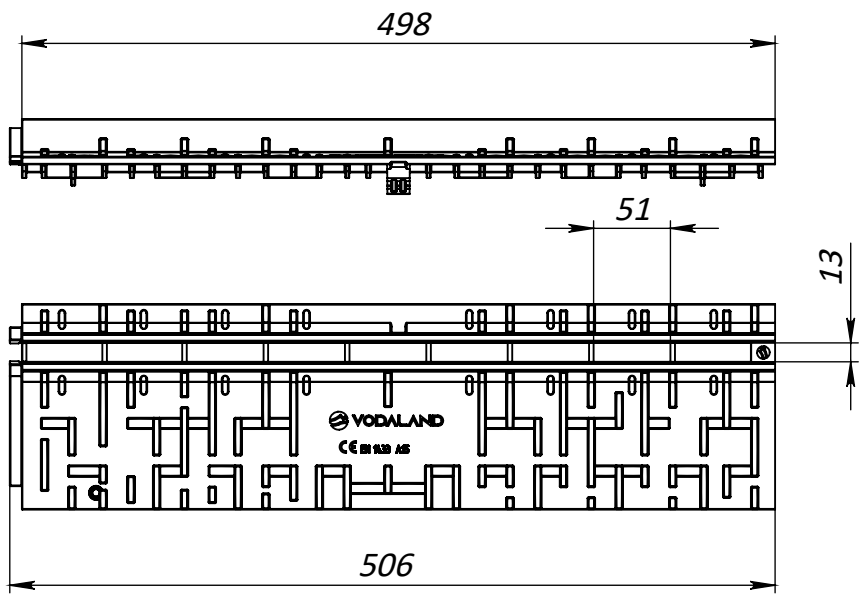

1. Area of water intake slots 56.47 sq cm;
2. Deviation of the actual weight of the nominal can be up to 8%

UNLESS OTHERWISE SPECIFIED: DIMENSIONS ARE IN MILLIMETERS SURFACE FINISH: TOLERANCES: ISO 2768-c LINEAR: ANGULAR:				FINISH:		DO NOT SCALE DRAWING		REVISION	
						TITLE: Plastic slot drain L-type H25 for channel Base DN100 A15 Load class: A15			
				MATERIAL: Plastic		Article: 2087-L-25		A4	
				WEIGHT: 0.40 kg		SCALE:1:5		SHEET 1 OF 1	

6 5 4 3 2 1

D
C
B
A

D
C
B
A

NSHR-10.16.50-SS 209875-L-25

Primary Usage

Reference No.

Sign. and date

Copy inv. No.

Repl. Inv. No.

Sign. and date

Orig. Inv. No.

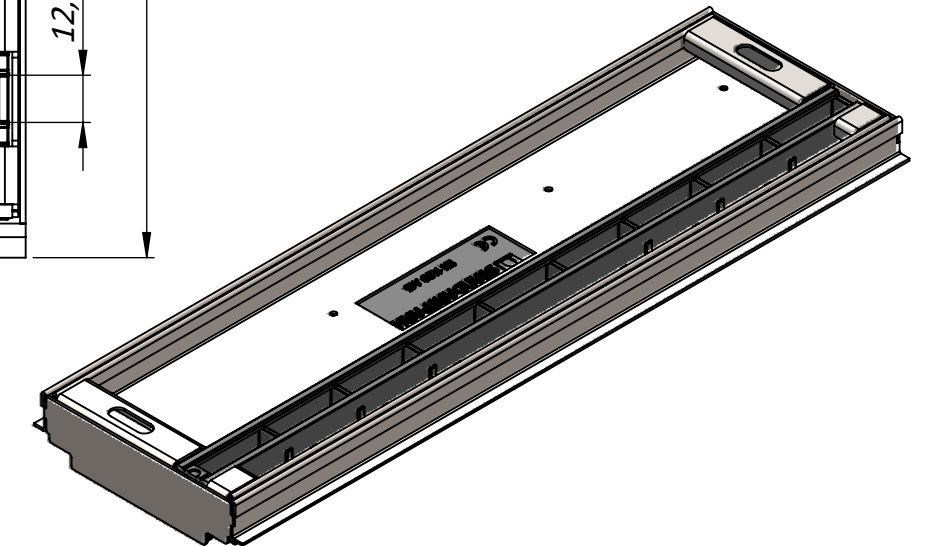
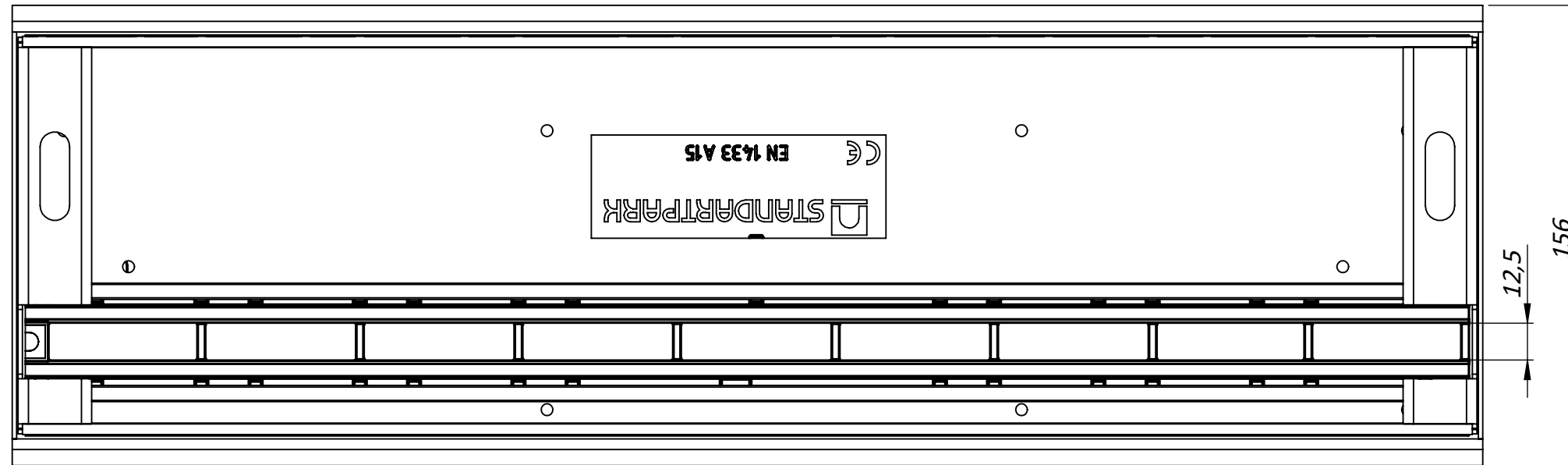
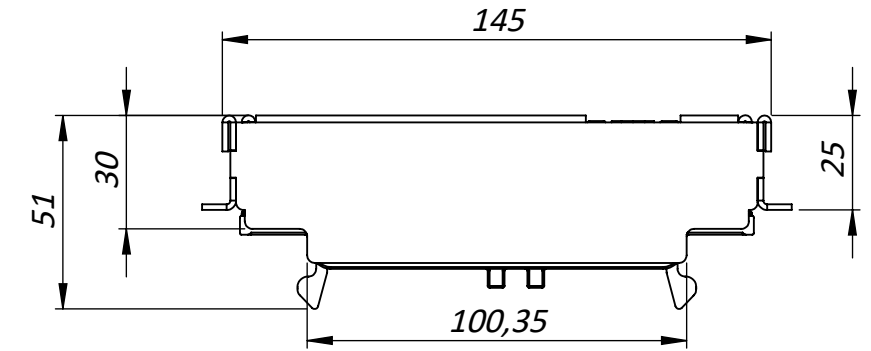
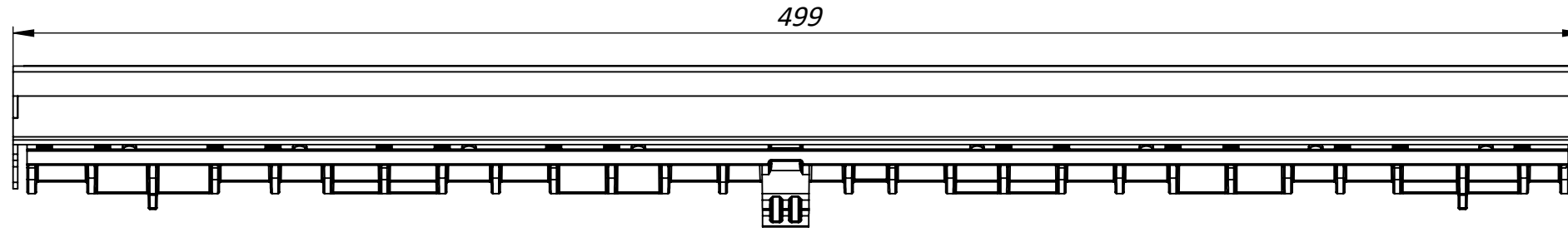

1. Deviation of the actual weight of the nominal can be up to 8%
Hydraulic cross-sectional area - 564,7 cm

					Art. 209875-L-25		
					NSHR-10.16.50-SS 209875-L-25		
					Cleaning module H25		
					Load Class A15		
					Let.	Weight	Scale
						2.064	1:2
					Sheet	Sheets 1	